

DESCRIPTION: USB MINI-B DIP SOLDER

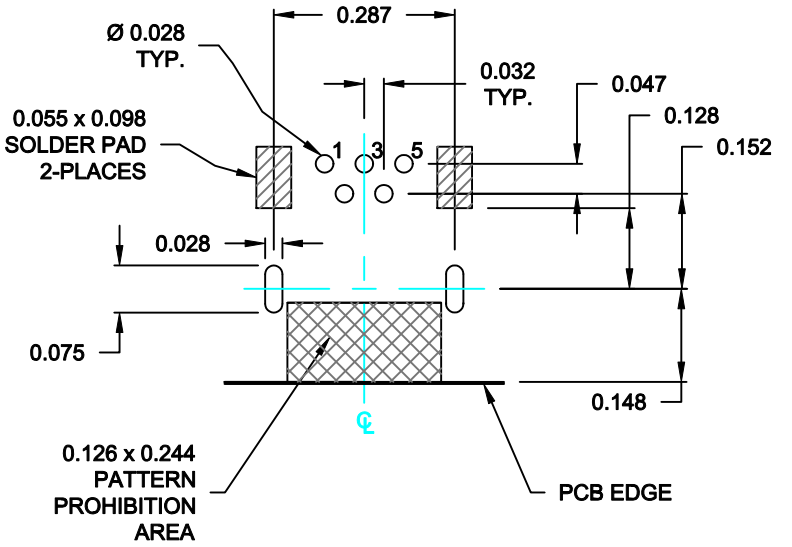
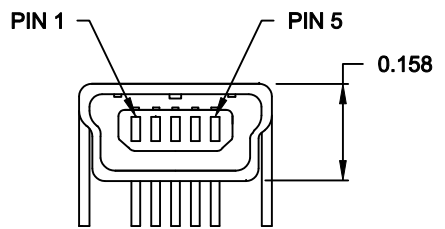
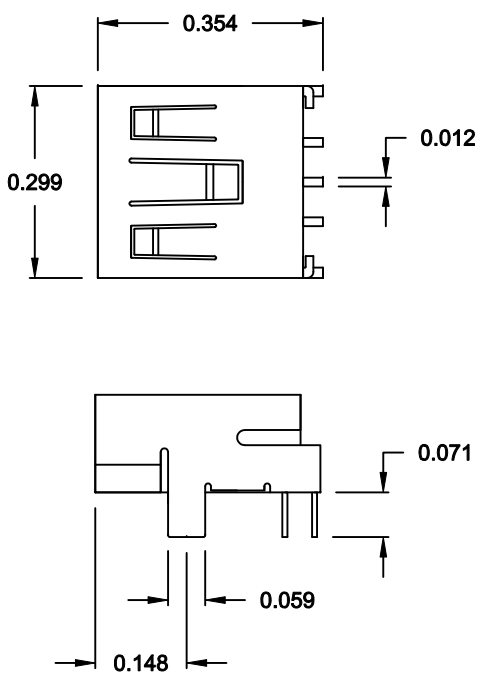

RECOMMENDED PCB LAYOUT
SCALE = 3 : 1

ELECTRICAL:

- CONTACT CURRENT RATING: 1.0 AMPS
- DIELECTRIC WITHSTANDING VOLTAGE: 100VAC
- INSULATION RESISTANCE: 100 MegOhms Min.
- CONTACT RESISTANCE: 30 MilliOhms Max.
- OPERATING TEMPERATURE: -25°C TO +70°C

MECHANICAL:

- MATING FORCE: 3.5 Kg Max.
- UNMATING FORCE: 0.5 Kg Min.

MATERIALS:

- CONTACTS: PHOSPHOR BRONZE
- INSULATOR: THERMOPLASTIC PA9T UL 94V-0
- SHELL: BRASS

PLATING:

- CONTACTS: 30u" GOLD (MATING AREA)
TIN (LEAD FREE) SOLDER TAILS
- SHELL: NICKEL PLATED
- USB VERSION: 2.0

DO NOT SCALE FROM DRAWING

	THESE DRAWINGS AND SPECIFICATIONS ARE THE PROPERTY OF NorComp AND SHALL NOT BE REPRODUCED, COPIED OR USED AS THE BASIS FOR THE MANUFACTURE OR SALE OF APPARATUS WITHOUT WRITTEN PERMISSION.		DRAWN: PAM JENKINS	DATE: 9-15-05
			CHECKED:	DATE:
<h1>NorComp</h1>		SCALE:	SHEET 1 OF 1	REV 3
		DWG NO. 065-005-122R030		

RoHS COMPLIANT