

Selector Settings Knob

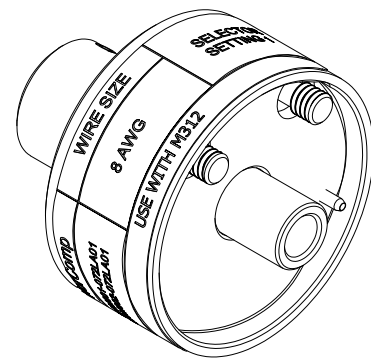

TOOLING INSTRUCTIONS	
1.	FOLLOW DMC M312 DATASHEET INCLUDED WITH THIS PRODUCT
2.	USE POSITIONER INCLUDED (TP1919)
3.	USE SELECTOR SETTINGS SHOWN ON POSITIONER DEPENDANT ON WIRE AWG USED
4.	8mm-9MM WIRE STRIP DISTANCE IS RECOMMENDED (SEE CONTACT DRAWING FOR SPECIFIC RECOMMENDATION) // PUSH STRIPPED WIRE FULLY INTO CONTACT BEFORE CRIMPING

NorComp	WIRE SIZE	SELECTOR SETTING 1
680M001-072LA01 680M002-072LA01	8 AWG	
USE WITH M312		

RoHS COMPLIANT



THESE DRAWINGS AND SPECIFICATIONS ARE THE PROPERTY OF NorComp AND SHALL NOT BE REPRODUCED, COPIED OR USED AS THE BASIS FOR THE MANUFACTURE OR SALE OF APPARATUS WITHOUT WRITTEN PERMISSION.

DRAWN:
J. KADEL
DATE:
03/15/2024

UNITS = mm

DO NOT SCALE FROM DRAWING

NorComp

SCALE: NTS	SHEET 1 OF 1	REV 2
DWG NO. 680M702-072-005		