

NOTE:

MATERIAL

- HOUSING
- FLANGE
- CONTACT
- SHELL
- O-RING
- SEALING COMPOUND
- HARDWARE

- PBT UL94V-0, BLACK
- PBT UL94V-0, BLACK
- BRASS, PLATING P/N KEY BELOW
- STEEL, NICKEL
- SILICONE
- EPOXY
- BRASS; NICKEL PLATED

ELECTRICAL

- POWER CONTACT RATED CURRENT P/N KEY BELOW
- VOLTAGE 1000 VAC 1 MIN
- INSULATOR RESISTANCE 5 GOhms MIN.
- POWER CONTACT RESISTANCE 2.0 mOhms MAX.
- WATER PROOF IP67
- ENVIRONMENT
- OPERATION TEMPERATURE -25°C TO +85°C

HARDWARE OPTIONS

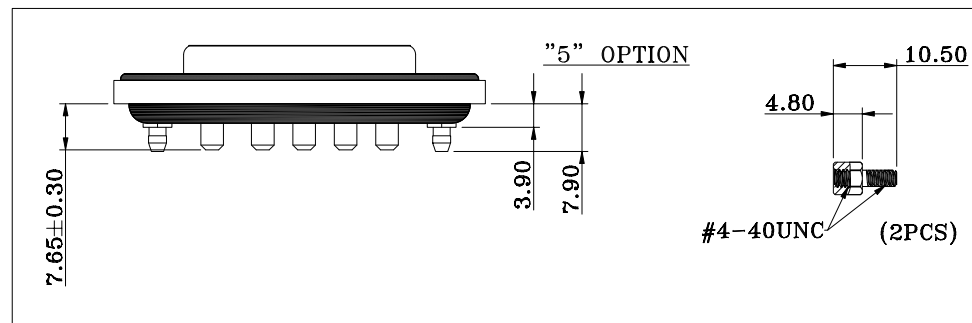
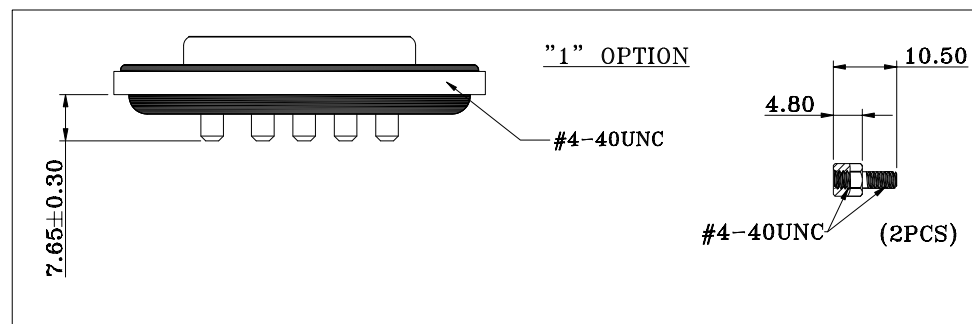

CDFV5W5213LYYY

- SERIES _____
- CDF = COMBO DSUB FLANGE
- CONTACT TYPE _____
- V = VERTICAL PCB MOUNT
- POSITION _____
- 5W5
- GENDER _____
- 2 = FEMALE
- POWER CONTACT AMPERAGE _____
- 2 = 20 AMPS
- 4 = 40 AMPS
- HARDWARE OPTIONS _____
- 1 = 4-40 THREADED INSERTS/4-40 JACKSCREWS
- 5 = 4-40 THREADED BOARD LOCKS & 4-40 JACKSCREWS
- CONTACT PLATING OPTIONS _____
- 1 = GOLD FLASH
- 2 = 30u" GOLD PLATING

RoHS COMPLIANT



THESE DRAWINGS AND SPECIFICATIONS ARE THE PROPERTY OF NorComp AND SHALL NOT BE REPRODUCED, COPIED OR USED AS THE BASIS FOR THE MANUFACTURE OR SALE OF APPARATUS WITHOUT WRITTEN PERMISSION.

DRAWN: J. KADEL
 DATE: 06/03/2020

TOLERANCES
 X. ±0.40
 .X ±0.30
 .XX ±0.20
 .XXX ±0.10

UNITS = mm

DO NOT SCALE FROM DRAWING

NorComp

SCALE: NTS	SHEET 1 OF 2	REV 1
DWG NO. CDFV5W5213LYYY		

**** ϕ 3.20MM HOLES NOT NEEDED FOR "1" HARDWARE OPTION**

20 AMP CONFIGURATION

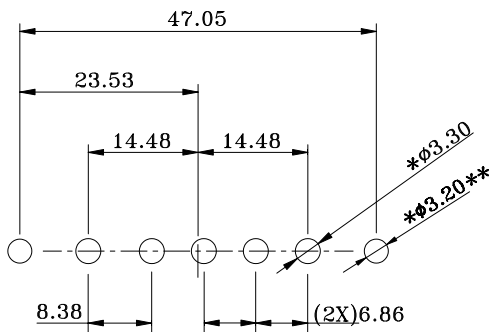

40 AMP CONFIGURATION

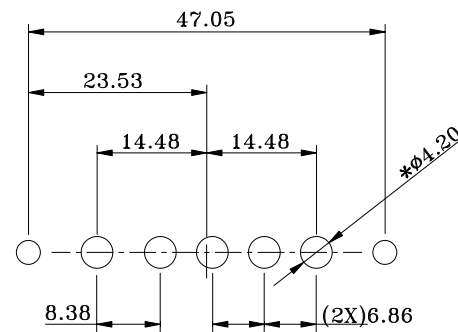

RECOMMENDED PCB LAYOUT

*TYPICAL // HOLE SIZE MAY NOT BE SUITABLE FOR YOUR SPECIFIC APPLICATION

RoHS COMPLIANT



THESE DRAWINGS AND SPECIFICATIONS ARE THE PROPERTY OF NorComp AND SHALL NOT BE REPRODUCED, COPIED OR USED AS THE BASIS FOR THE MANUFACTURE OR SALE OF APPARATUS WITHOUT WRITTEN PERMISSION.

DRAWN:

J. KADEL

DATE:

06/03/2020

TOLERANCES

X. \pm 0.40
 .X \pm 0.30
 .XX \pm 0.20
 .XXX \pm 0.10

UNITS = mm

DO NOT SCALE FROM DRAWING

NorComp

SCALE:

NTS

SHEET

OF

2

2

REV

1

DWG NO.

CDFV5W5213LYYY