

**NOTE:**

**MATERIAL**

HOUSING	PBT UL94V-0, BLACK
FLANGE	PBT UL94V-0, BLACK
CONTACT	BRASS, PLATING P/N KEY BELOW
SHELL	STEEL, NICKEL
O-RING	SILICONE
SEALING COMPOUND	EPOXY
HARDWARE	BRASS; NICKEL PLATED

**ELECTRICAL**

SIGNAL CONTACT RATED CURRENT	5A
POWER CONTACT RATED CURRENT	P/N KEY BELOW
VOLTAGE	1000 VAC 1 MIN
INSULATOR RESISTANCE	5 GOhms MIN.
SIGNAL CONTACT RESISTANCE	10 mOhms MAX.
POWER CONTACT RESISTANCE	2.0 mOhms MAX.
WATER PROOF	IP67

**ENVIRONMENT**

OPERATION TEMPERATURE	-25°C TO +85°C
-----------------------	----------------

**HARDWARE OPTIONS**

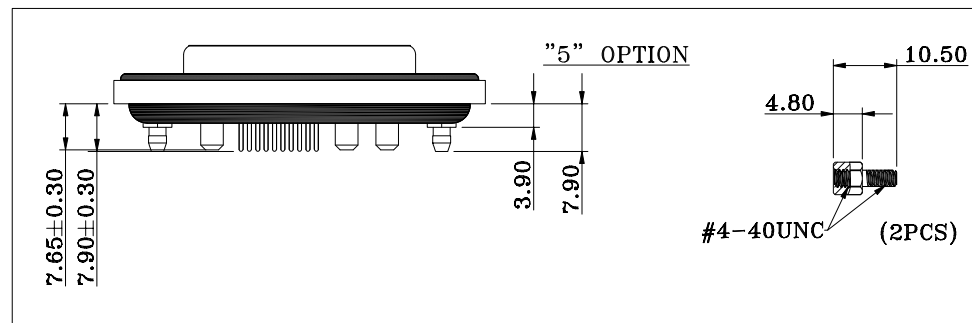
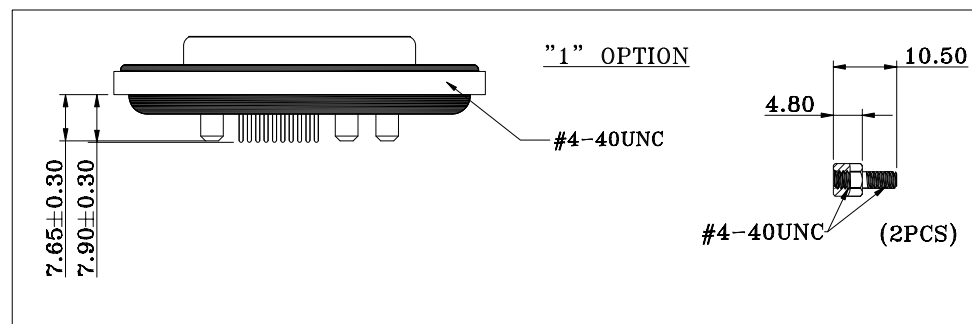

CDFV13W3213LYYY

SERIES	CDF = COMBO DSUB FLANGE
CONTACT TYPE	V = VERTICAL PCB MOUNT
POSITION	13W3
GENDER	2 = FEMALE
POWER CONTACT AMPERAGE	2 = 20 AMPS 4 = 40 AMPS
HARDWARE OPTIONS	1 = 4-40 THREADED INSERTS/4-40 JACKSCREWS 5 = 4-40 THREADED BOARD LOCKS & 4-40 JACKSCREWS
CONTACT PLATING OPTIONS	1 = GOLD FLASH 2 = 30u" GOLD PLATING

RoHS COMPLIANT



THESE DRAWINGS AND SPECIFICATIONS ARE THE PROPERTY OF NorComp AND SHALL NOT BE REPRODUCED, COPIED OR USED AS THE BASIS FOR THE MANUFACTURE OR SALE OF APPARATUS WITHOUT WRITTEN PERMISSION.

DRAWN:  
J. KADEL  
DATE:  
04/27/2020

**TOLERANCES**

X.	±0.40
.X	±0.30
.XX	±0.20
.XXX	±0.10

UNITS = mm

DO NOT SCALE FROM DRAWING

NorComp

SCALE: NTS	SHEET 1	OF 2	REV 1
DWG NO.			CDFV13W3213LYYY

**\*\* $\phi$ 3.20MM HOLES NOT NEEDED FOR "1" HARDWARE OPTION**

**20 AMP CONFIGURATION**

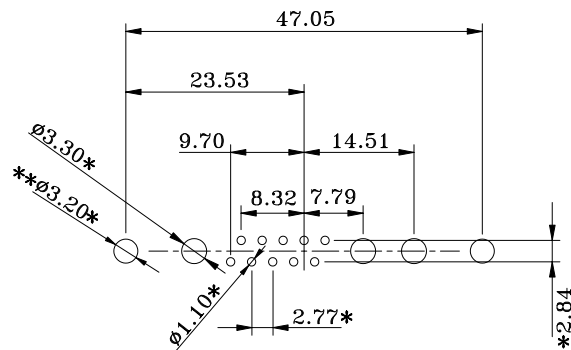

**40 AMP CONFIGURATION**

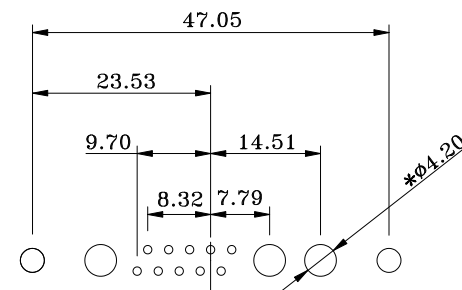

**RECOMMENDED PCB LAYOUT**

**\*TYPICAL // HOLE SIZE MAY NOT BE SUITABLE FOR YOUR SPECIFIC APPLICATION**

**RoHS COMPLIANT**



THESE DRAWINGS AND SPECIFICATIONS ARE THE PROPERTY OF NorComp AND SHALL NOT BE REPRODUCED, COPIED OR USED AS THE BASIS FOR THE MANUFACTURE OR SALE OF APPARATUS WITHOUT WRITTEN PERMISSION.

DRAWN:  
J. KADEL  
DATE:  
04/27/2020

**TOLERANCES**

X.  $\pm 0.40$   
.X  $\pm 0.30$   
.XX  $\pm 0.20$   
.XXX  $\pm 0.10$

UNITS = mm

**DO NOT SCALE FROM DRAWING**

**NorComp**

SCALE: NTS	SHEET 2	OF 2	REV 1
---------------	------------	---------	----------

DWG NO. **CDFV13W3213LYYY**