

**NOTE:**

**MATERIAL**

HOUSING	PBT UL94V-0, BLACK
FLANGE	PBT UL94V-0, BLACK
CONTACT	BRASS, PLATING P/N KEY BELOW
SHELL	STEEL, NICKEL
O-RING	SILICONE
SEALING COMPOUND	EPOXY
HARDWARE	BRASS; NICKEL PLATED

**ELECTRICAL**

SIGNAL CONTACT RATED CURRENT	5A
POWER CONTACT RATED CURRENT	P/N KEY BELOW
VOLTAGE	1000 VAC 1 MIN
INSULATOR RESISTANCE	5 GOhms MIN.
SIGNAL CONTACT RESISTANCE	10 mOhms MAX.
POWER CONTACT RESISTANCE	2.0 mOhms MAX.
WATER PROOF	IP67

**ENVIRONMENT**

OPERATION TEMPERATURE	-25°C TO +85°C
-----------------------	----------------

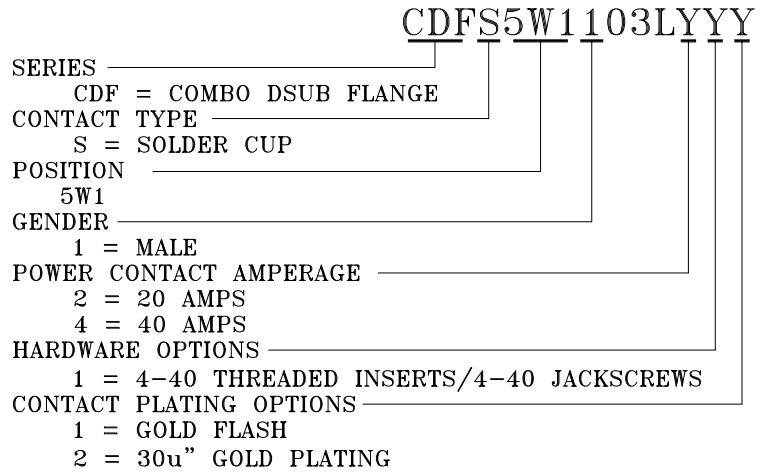
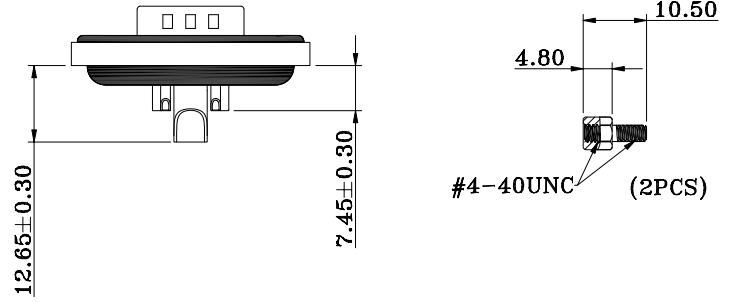
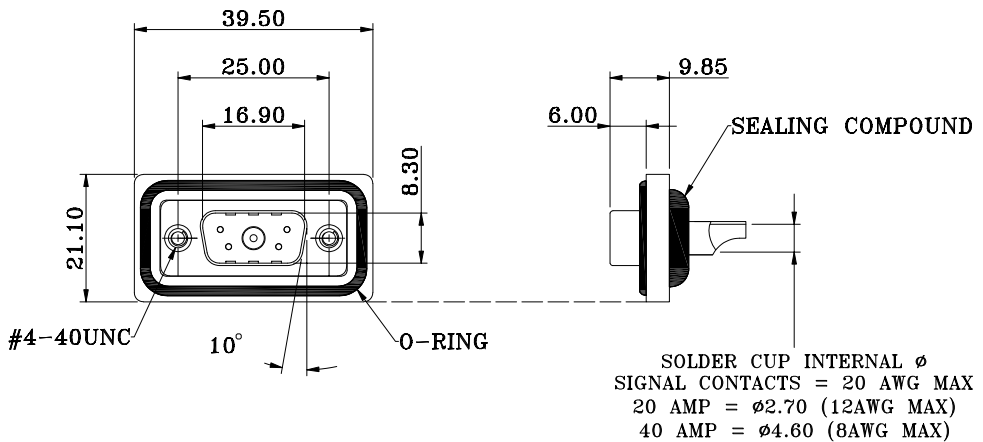

RoHS COMPLIANT



THESE DRAWINGS AND SPECIFICATIONS ARE THE PROPERTY OF NorComp AND SHALL NOT BE REPRODUCED, COPIED OR USED AS THE BASIS FOR THE MANUFACTURE OR SALE OF APPARATUS WITHOUT WRITTEN PERMISSION.

DRAWN: J. KADEL  
DATE: 06/02/2020

TOLERANCES  
X. ±0.40  
.X ±0.30  
.XX ±0.20  
.XXX ±0.10

UNITS = mm DO NOT SCALE FROM DRAWING



SCALE: NTS	SHEET 1 OF 1	REV 1
DWG NO. CDFS5W1103LYYY		