

CONTACT ϕ AT TERMINATION SIDE
 SIGNAL CONTACTS = $\phi 0.65$
 20 AMP = $\phi 2.80$
 40 AMP = $\phi 3.75$

NOTE:

MATERIAL

- HOUSING
- FLANGE
- CONTACT
- SHELL
- O-RING
- SEALING COMPOUND
- HARDWARE

- PBT UL94V-0, BLACK
- PBT UL94V-0, BLACK
- BRASS, PLATING P/N KEY BELOW
- STEEL, NICKEL
- SILICONE
- EPOXY
- BRASS; NICKEL PLATED

ELECTRICAL

- POWER CONTACT RATED CURRENT
- VOLTAGE
- INSULATOR RESISTANCE
- POWER CONTACT RESISTANCE
- WATER PROOF

- P/N KEY BELOW
- 1000 VAC 1 MIN
- 5 GOhms MIN.
- 2.0 mOhms MAX.
- IP67

ENVIRONMENT

- OPERATION TEMPERATURE

- 25°C TO +85°C

HARDWARE OPTIONS

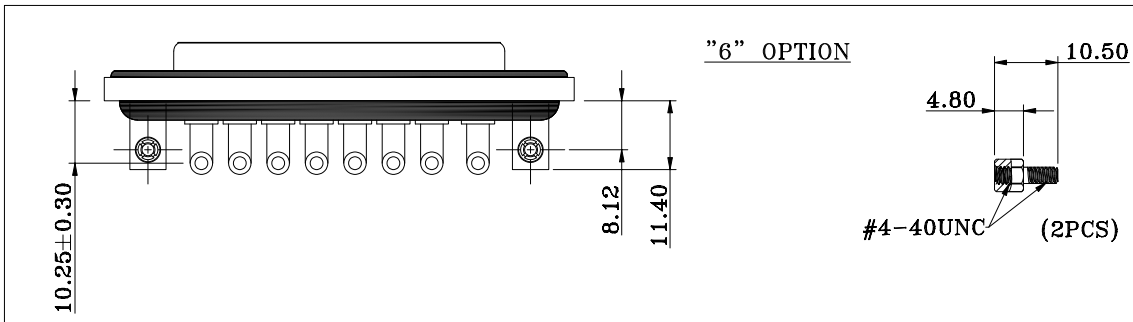
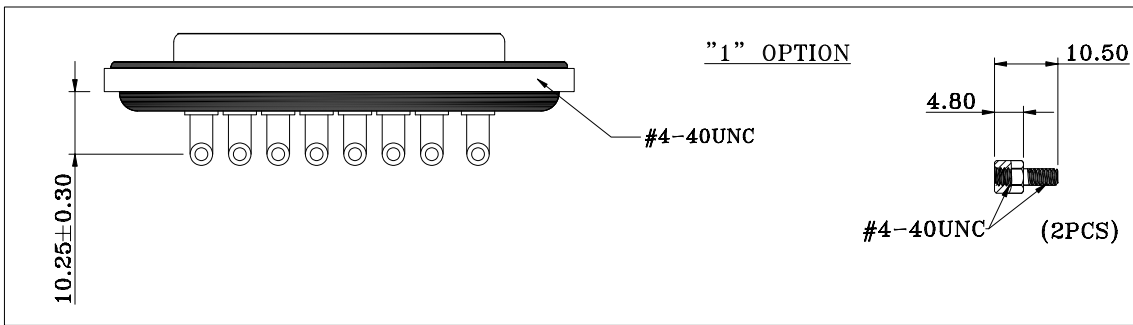

CDFR8W8213LYYY

- SERIES _____
- CDF = COMBO DSUB FLANGE
- CONTACT TYPE _____
- R = RIGHT ANGLE PCB MOUNT
- POSITION _____
- 8W8
- GENDER _____
- 2 = FEMALE
- POWER CONTACT AMPERAGE _____
- 2 = 20 AMPS
- 4 = 40 AMPS
- HARDWARE OPTIONS _____
- 1 = 4-40 THREADED INSERTS/4-40 JACKSCREWS
- 6 = 4-40 THREADED BRACKETS &
 BOARD LOCKS/4-40 JACKSCREWS
- CONTACT PLATING OPTIONS _____
- 1 = GOLD FLASH
- 2 = 30u" GOLD PLATING

RoHS COMPLIANT



THESE DRAWINGS AND SPECIFICATIONS ARE THE PROPERTY OF NorComp AND SHALL NOT BE REPRODUCED, COPIED OR USED AS THE BASIS FOR THE MANUFACTURE OR SALE OF APPARATUS WITHOUT WRITTEN PERMISSION.

DRAWN:
J. KADEL
DATE:
06/04/2020

TOLERANCES
 X. ± 0.40
 .X ± 0.30
 .XX ± 0.20
 .XXX ± 0.10

UNITS = mm

DO NOT SCALE FROM DRAWING



SCALE: NTS	SHEET 1	OF 2	REV 1
DWG NO. CDFR8W8213LYYY			

**** ϕ 3.20MM HOLES NOT NEEDED FOR "1" HARDWARE OPTION**

20 AMP CONFIGURATION

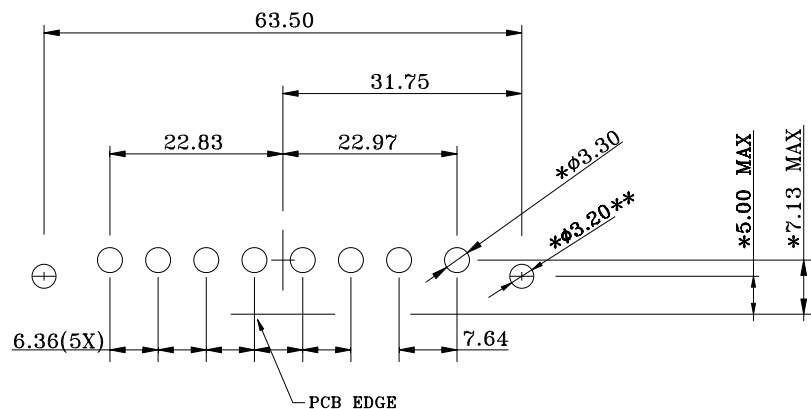

40 AMP CONFIGURATION

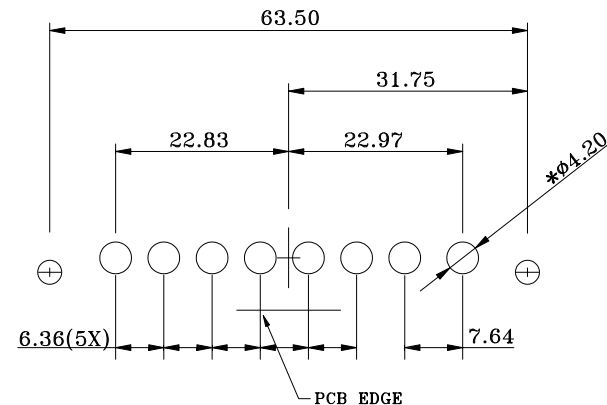

RECOMMENDED PCB LAYOUT

***TYPICAL // HOLE SIZE MAY NOT BE SUITABLE FOR YOUR SPECIFIC APPLICATION**

RoHS COMPLIANT



THESE DRAWINGS AND SPECIFICATIONS ARE THE PROPERTY OF NorComp AND SHALL NOT BE REPRODUCED, COPIED OR USED AS THE BASIS FOR THE MANUFACTURE OR SALE OF APPARATUS WITHOUT WRITTEN PERMISSION.

DRAWN:
J. KADEL
DATE:
06/04/2020

TOLERANCES
X. \pm 0.40
.X \pm 0.30
.XX \pm 0.20
.XXX \pm 0.10

UNITS = mm

DO NOT SCALE FROM DRAWING

NorComp

SCALE: NTS	SHEET 2	OF 2	REV 1
DWG NO.		CDFR8W8213LYYY	