

DESCRIPTION: FEMALE - DIP SOLDER / MACHINED - ECONOMY

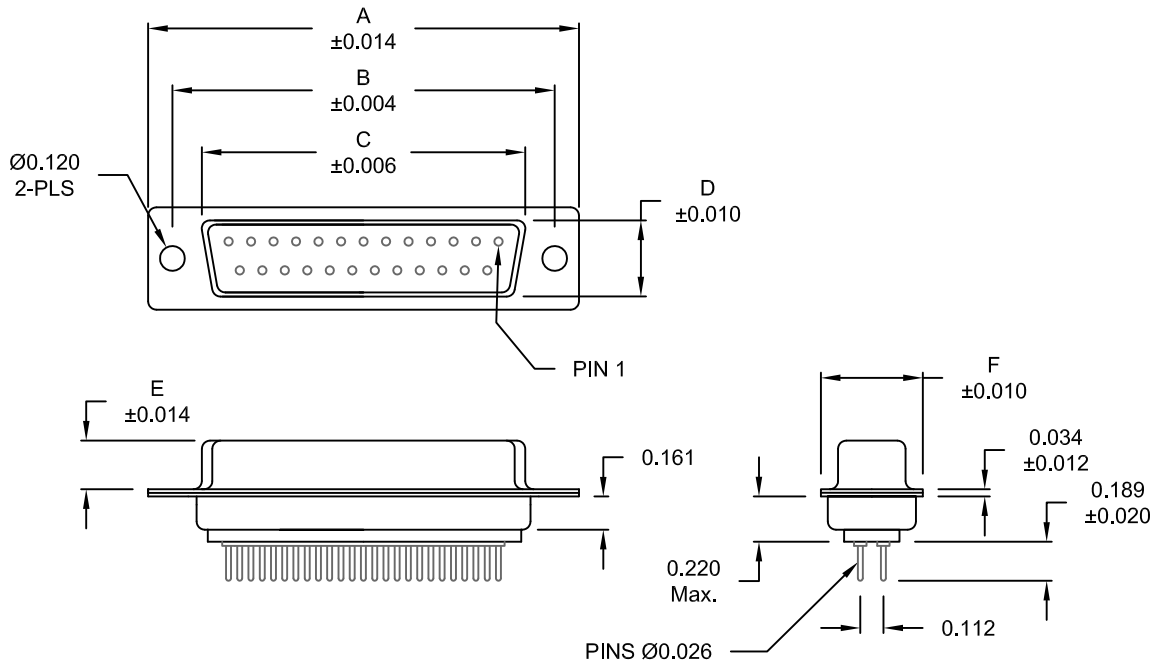

MATERIAL:

SHELL: STEEL, NICKEL OR TIN PLATED
 INSULATOR: UL 94V-O RATED, WHITE, PA6T
 PROCESS TEMP.: 260° PROCESS TEMPERATURE
 CONTACT: BRASS

ELECTRICAL:

CURRENT RATING: 5 AMPS
 CONTACT RESISTANCE: 15 mOhms Max.
 INSULATION RESISTANCE: 1,000 MOhms min.
 WORKING VOLTAGE: 250VAC
 TEMPERATURE: -55° C TO 125° C

No. OF PINS	DIMENSIONS					
	A	B	C	D	E	F
9	1.213	0.984	0.642	0.311	0.236	0.496
	30.80	24.99	16.30	7.90	5.99	12.60
15	1.541	1.312	0.970	0.311	0.236	0.496
	39.15	33.32	24.65	7.90	5.99	12.60
25	2.087	1.852	1.512	0.311	0.236	0.496
	53.00	47.04	38.40	7.90	5.99	12.60
37	2.728	2.500	2.157	0.311	0.236	0.496
	69.30	63.50	54.80	7.90	5.99	12.60
50	2.638	2.406	2.055	0.429	0.240	0.602
	67.00	61.10	52.20	10.90	6.10	15.30

172-EYY-21YRY1

SERIES _____
 POSITIONS _____
 E09 _____
 E15 _____
 E25 _____
 E37 _____
 E50 _____
 GENDER _____
 2 = FEMALE
 TERMINATION _____
 1 = DIP SOLDER
 SHELL PLATING _____
 2 = TIN
 3 = NICKEL
 RoHS COMPLIANT _____
 HARDWARE OPTIONS _____
 00 = NO HARDWARE
 01 = .098" CLINCH NUT (BOARD SIDE)
 02 = .236" CLINCH NUT (BOARD SIDE)
 03 = .236" CLINCH NUT (MOUNTING SIDE)
 05 = .237" 4-40 BOARD LOCK
 08 = .228" 4-40 BOARD LOCK
 90 = .237" 4-40 BOARD LOCK
 FOR 0.093" BOARD MAX.
 91 = .237" 4-40 SPACER/ BOARD LOCK
 92 = .237" 4-40 SPACER/ BOARD LOCK
 FOR 0.093" BOARD MAX.
 PLATING OPTIONS _____
 1 = GOLD FLASH
 2 = 30MICRO-INCH GOLD
 5 = 15 MICRO-INCH GOLD

UNITS = inch [mm]

DO NOT SCALE FROM DRAWING

RoHS COMPLIANT

	THESE DRAWINGS AND SPECIFICATIONS ARE THE PROPERTY OF NorComp AND SHALL NOT BE REPRODUCED, COPIED OR USED AS THE BASIS FOR THE MANUFACTURE OF SALE OF APPARATUS WITHOUT WRITTEN PERMISSION.	DRAWN: PAM JENKINS	DATE: 11-28-05
	<h1>NorComp</h1>	SCALE: NTS	SHEET 1 OF 3
		DWG NO. 172-EYY-21YRY1	

DESCRIPTION: PCB LAYOUT - STANDARD "D" - MALE & FEMALE

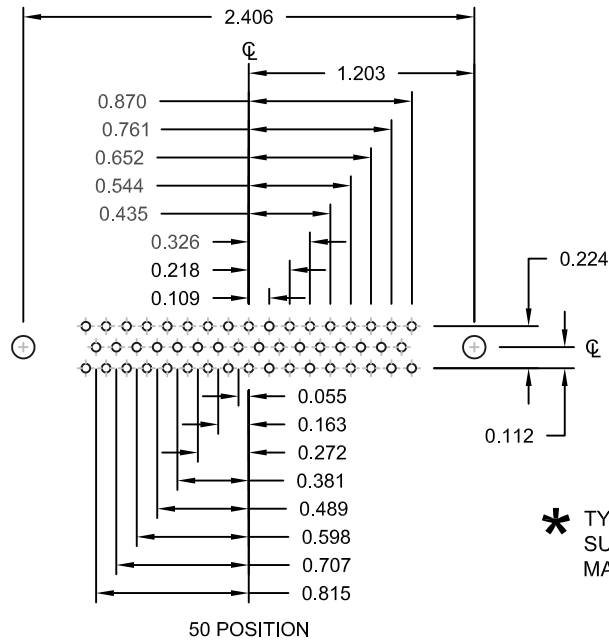
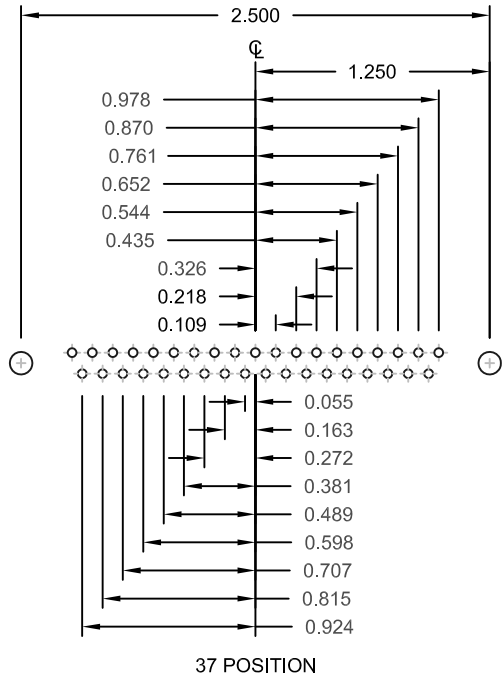
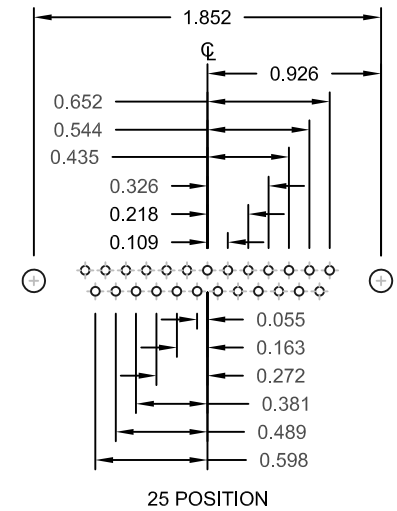
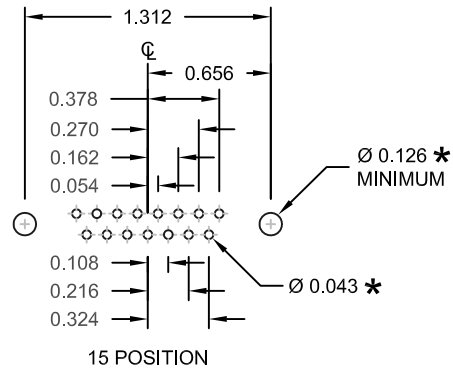
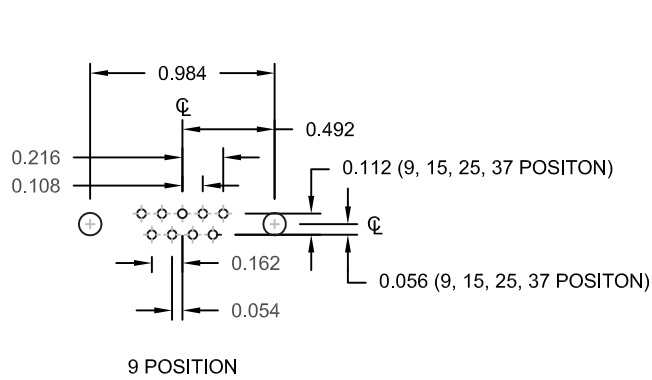

* TYP.
SUGGESTED SIZE
MAY NOT BE SUITABLE FOR ALL APPLICATIONS

UNITS = inch

DO NOT SCALE FROM DRAWING



THESE DRAWINGS AND SPECIFICATIONS ARE THE PROPERTY OF NorComp AND SHALL NOT BE REPRODUCED, COPIED OR USED AS THE BASIS FOR THE MANUFACTURE OF SALE OF APPARATUS WITHOUT WRITTEN PERMISSION.

DRAWN: PAM JENKINS		DATE: 11-28-05	
SCALE: NTS	SHEET 2	OF 3	REV 17
DWG NO. 172-EYY-21YRY1			

NorComp

DESCRIPTION: CLINCH NUT HARDWARE

ALL CLINCH-NUTS ARE 4-40 INTERNAL THREADS

TOLERANCE:

ALL DIMENSIONS ARE ±0.010

01X 0.098" (BOARD SIDE)

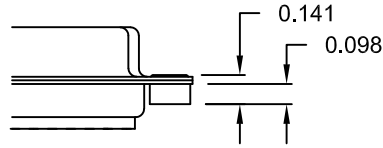

02X 0.236" (BOARD SIDE)

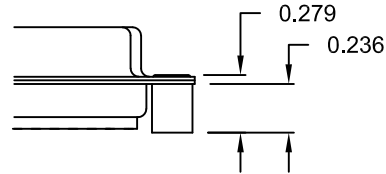

03X..... 0.236" (MATING SIDE)

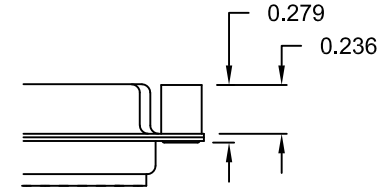

05X 0.237" (BOARD SIDE)

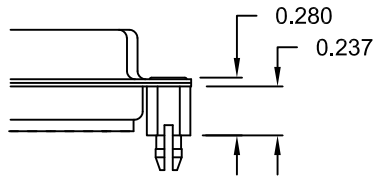

08X 0.228" (BOARD SIDE)

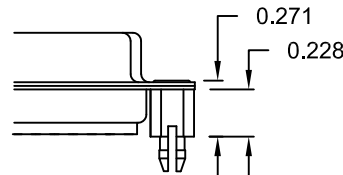

91X 0.237" BOARD SIDE

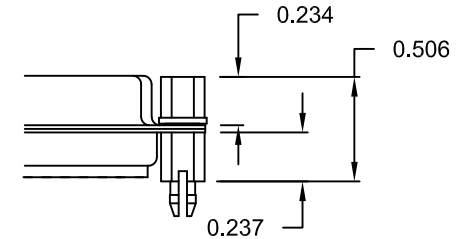

NOTE: 4-40 FEMALE SCREW LOCK IS REMOVABLE

90X 0.237" (BOARD SIDE)

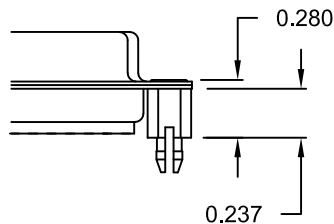

92X 0.237" BOARD SIDE

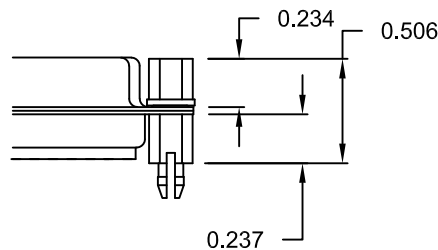

NOTE: 4-40 FEMALE SCREW LOCK IS REMOVABLE

UNITS = inch [mm]

DO NOT SCALE FROM DRAWING

NOTE: 90 & 92 OPTION FOR 0.093" MAX. BOARD THICKNESS



THESE DRAWINGS AND SPECIFICATIONS ARE THE PROPERTY OF NorComp AND SHALL NOT BE REPRODUCED, COPIED OR USED AS THE BASIS FOR THE MANUFACTURE OF SALE OF APPARATUS WITHOUT WRITTEN PERMISSION.

DRAWN: PAM JENKINS		DATE: 11-28-05	
SCALE: NTS	SHEET 3	OF 3	REV 17
DWG NO. 172-EYY-21YRY1			

RoHS COMPLIANT

NorComp