

\*\*SEE PAGE 2 FOR CONNECTOR DETAILS

WIRING SCHEMATIC

- PIN
- 1 = WHITE
  - 2 = BROWN
  - 3 = GREEN
  - 4 = YELLOW
  - 5 = GREY
  - 6 = PINK
  - 7 = BLUE
  - 8 = RED

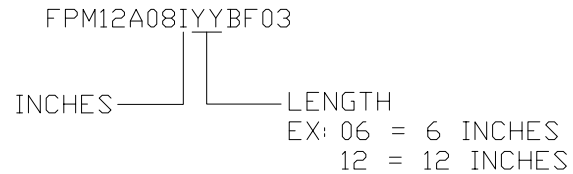

Full stainless steel variant successfully passes 96-hour salt spray testing per ASTM B117

NOTE: PACKAGED 10 PER BAG

RoHS COMPLIANT

UNITS = "as indicated" DO NOT SCALE FROM DRAWING



THESE DRAWINGS AND SPECIFICATIONS ARE THE PROPERTY OF NorComp AND SHALL NOT BE REPRODUCED, COPIED OR USED AS THE BASIS FOR THE MANUFACTURE OR SALE OF APPARATUS WITHOUT WRITTEN PERMISSION.

DRAWN:  
**G. BROWN**

DATE:  
**01/23/2019**

**NorComp**

SCALE: NTS	SHEET 1	OF 2	REV 3
DWG NO.		<b>FPM12A08IYYBF03</b>	

**SPECIFICATIONS:**

**MATERIALS:**

HOUSING: PBT, UL94 V-0, BLACK  
 CONTACTS: 10µ" GOLD PLATED BRASS  
 NUT: 316 STAINLESS STEEL  
 SHELL: 316 STAINLESS STEEL  
 ORING: EPDM, BLACK

**ELECTRICAL:**

RATED CURRENT: 2A  
 RATED VOLTAGE: 30V  
 INSULATION RESISTANCE: 100 MOhms MIN.  
 CONTACT RESISTANCE: 10 mOhms MAX.

**ENVIRONMENT:**

OPERATING TEMPERATURE: -40°C TO +85°C  
 WATER PROOF: IP67 / IP68

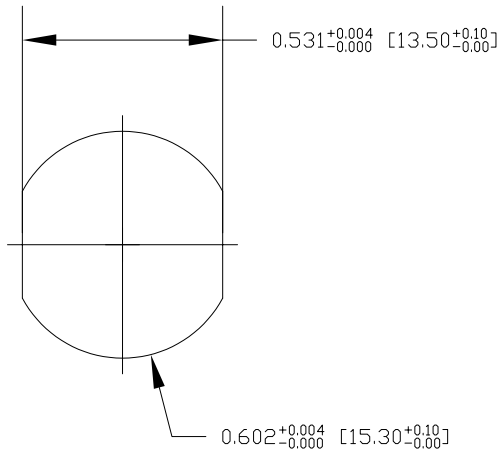

RECOMMENDED PANEL CUT-OUT

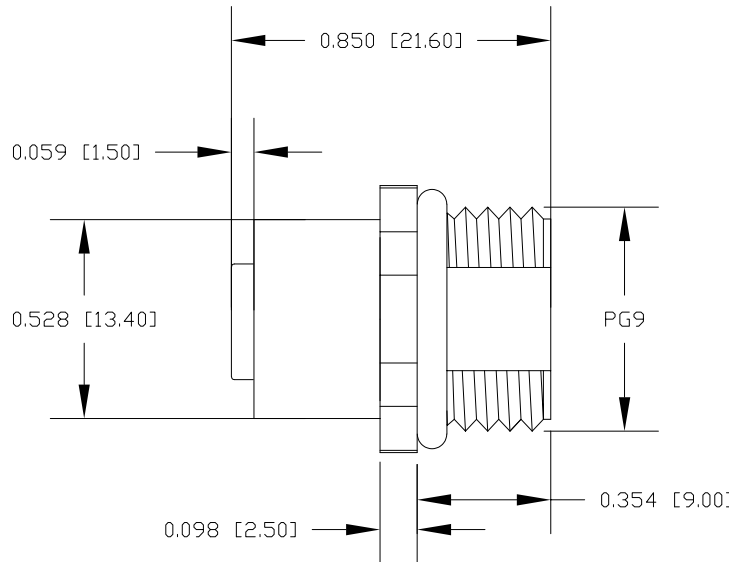
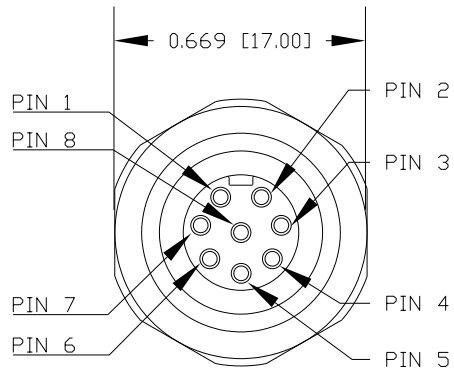
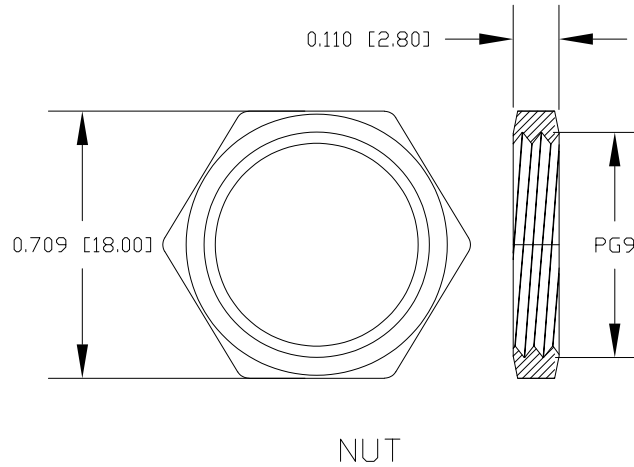

**RoHS COMPLIANT**

UNITS = inch [mm]

DO NOT SCALE FROM DRAWING



THESE DRAWINGS AND SPECIFICATIONS ARE THE PROPERTY OF NorComp AND SHALL NOT BE REPRODUCED, COPIED OR USED AS THE BASIS FOR THE MANUFACTURE OR SALE OF APPARATUS WITHOUT WRITTEN PERMISSION.

DRAWN:  
**G. BROWN**  
 DATE:  
**01/23/2019**

**NorComp**

SCALE: NTS	SHEET 2	OF 2	REV 3
DWG NO.		<b>FPM12A08IYYBF03</b>	