

DESCRIPTION: M12 MALE - PANEL MOUNT (REAR) - SOLDER CUP - 8 POS.

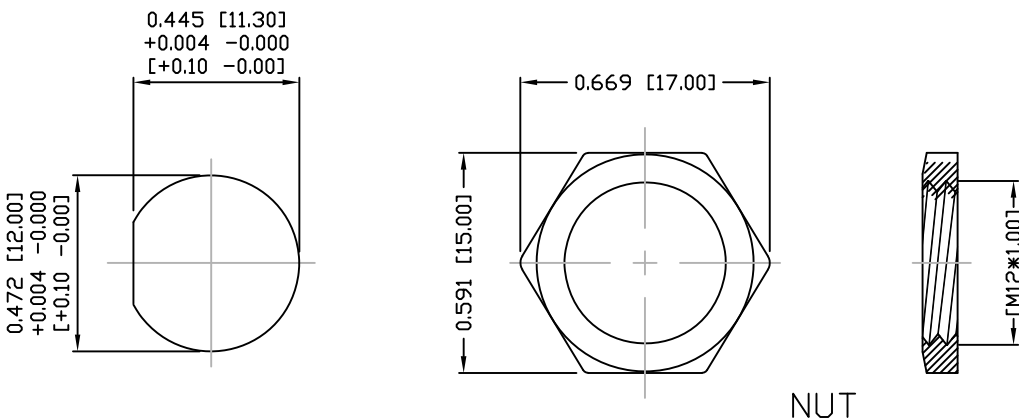

NOTE:

MATERIAL	
HOUSING:	PBT UL94V-0, BLACK
CONTACT:	BRASS
SHELL:	BRASS
NUT:	BRASS
O-RING:	EPDM, BLACK
O-RING (INTERNAL):	SILICONE, GREEN
FINISH	
CONTACT:	GOLD PLATED OVER 50u" NICKEL
SHELL:	NICKEL PLATED
NUT:	NICKEL PLATED
ELECTRICAL:	
RATED CURRENT:	2A
RATED VOLTAGE:	30V
INSULATION RESISTANCE:	100 MOhms MIN.
CONTACT RESISTANCE:	10 mOhms MAX.
WATER PROOF:	IP67
ENVIRONMENT:	
OPERATION TEMPERATURE:	-40°C TO +85°C
MAX WIRE AWG:	24

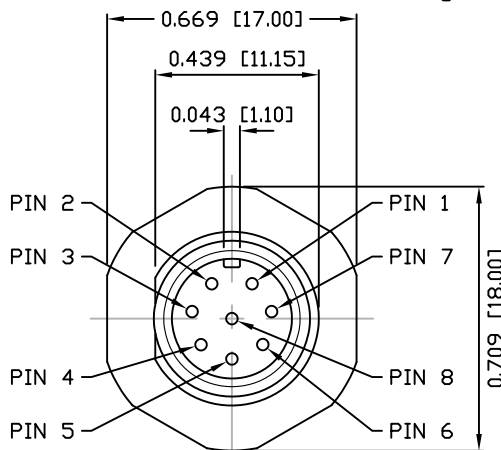
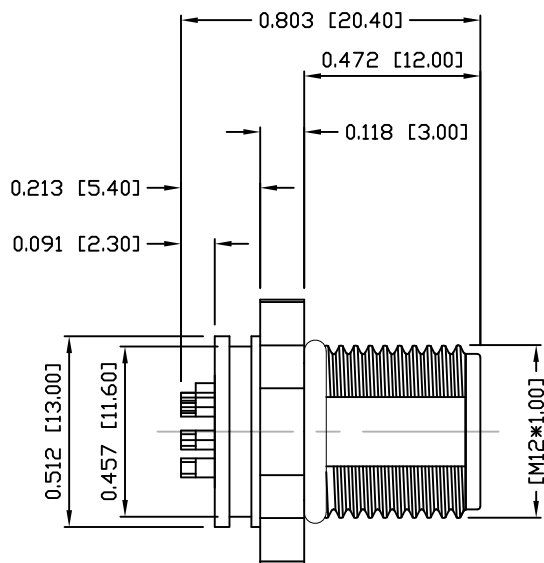

3 = BRASS/NICKEL SHELL & NUT  
S = STAINLESS STEEL SHELL & NUT

859-008-103R00Y

1 = GOLD FLASH  
4 = 10u" GOLD

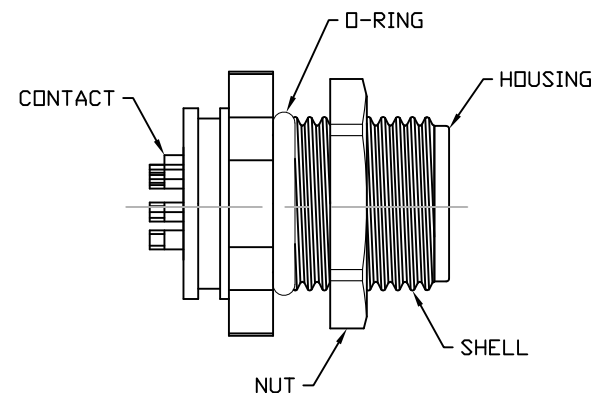

RoHS COMPLIANT

UNITS = INCHES [MM]

DO NOT SCALE FROM DRAWING



THESE DRAWINGS AND SPECIFICATIONS ARE THE PROPERTY OF NorComp AND SHALL NOT BE REPRODUCED, COPIED OR USED AS THE BASIS FOR THE MANUFACTURE OR SALE OF APPARATUS WITHOUT WRITTEN PERMISSION.

DRAWN: M. SIGMON

DATE: 03-07-16

NorComp

SCALE: NTS

SHEET 1 OF 1

REV 5

DWG NO. 859-008-103R00Y