

**SPECIFICATIONS:**

**MATERIALS:**

HOUSING: PA66, UL94 V-0, BLACK  
 CONTACTS: 10u" GOLD PLATED BRASS  
 NUT: NICKEL PLATED BRASS  
 SHELL: ZINC ALLOY  
 ORING: EPDM

**ELECTRICAL:**

RATED CURRENT: 4A  
 RATED VOLTAGE: 60V  
 INSULATION RESISTANCE: 100 MOhms  
 CONTACT RESISTANCE: 10 mOhms  
 MAX WIRE AWG: 22

**ENVIRONMENT:**

OPERATING TEMPERATURE: -40°C TO +85°C  
 WATER PROOF: IP67

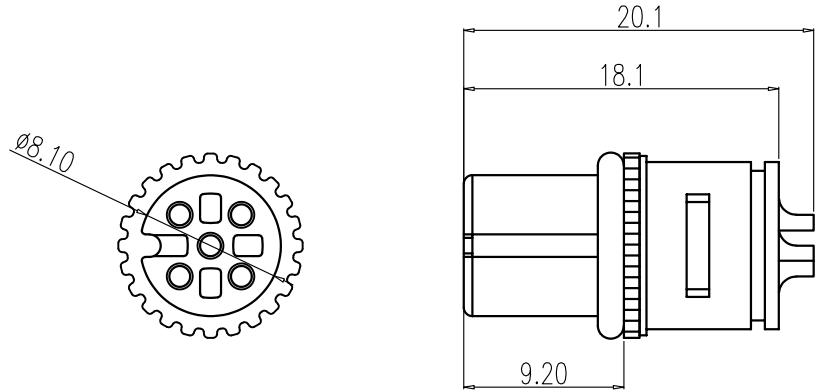

HOUSING & O-RING & SHELL

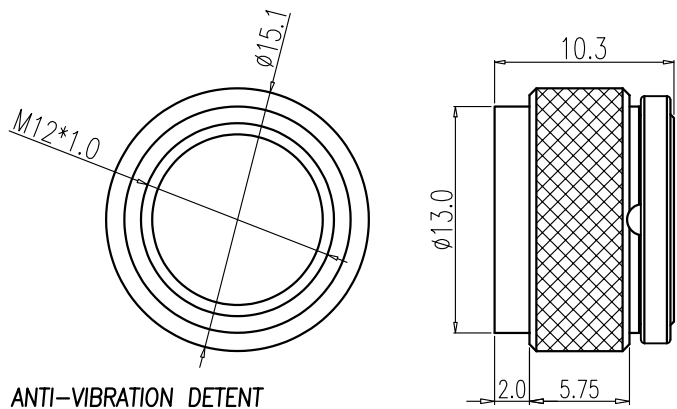

NUT & ANTI-VIBRATION DETENT

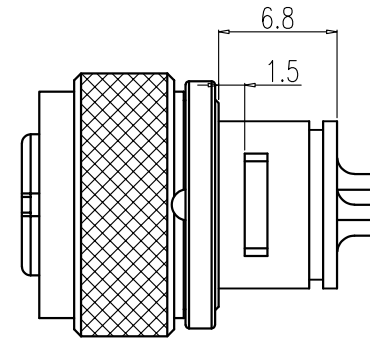

ASSEMBLY

**\*PLEASE NOTE THAT THE ANTI-VIBRATION DETENT IS MADE FROM PLASTIC AND IS NOT DESIGNED TO WITHSTAND MATING AND UN-MATING CYCLING; THIS WILL RESULT IN FAILURE OF THE ANTI-VIBRATION DETENT\***

RoHS COMPLIANT

UNITS = mm

DO NOT SCALE FROM DRAWING



THESE DRAWINGS AND SPECIFICATIONS ARE THE PROPERTY OF NorComp AND SHALL NOT BE REPRODUCED, COPIED OR USED AS THE BASIS FOR THE MANUFACTURE OR SALE OF APPARATUS WITHOUT WRITTEN PERMISSION.

DRAWN: J. KADEL  
 DATE: 10/24/2022

**NorComp**

SCALE: NTS	SHEET 1 OF 1	REV 1
DWG NO. 858VA05-203RLS4		