

**ASSEMBLY INSTRUCTIONS:**

1. SLIDE PLASTIC COVER OVER CABLE END
2. PREPARE CABLE ENDS, CONNECT TO CONNECTOR
3. PLACE CABLE IN STRAIN RELIEF AREA OF CONNECTOR COVER MAKING SURE CABLE JACKET IS BELOW STRAIN RELIEF CRIMP AREA
4. IF CABLE IS SHIELDED, FOLD SHIELD AND/OR GROUND WIRE BACK SO IT WILL BE UNDER THE CABLE CRIMP. CUT ANY EXCESS WIRE SO IT DOES NOT STICK OUT OF THE CONNECTOR COVER
5. CRIMP STRAIN RELIEF AROUND CABLE USING STANDARD CABLE CRIMPING TOOL CORRECTLY SIZED FOR THE CABLE BEING USED
6. SNAP THE SPRING LATCHES INTO POSITION ON THE OTHER CONNECTOR COVER. PLACE THE CONNECTOR COVER OVER THE CABLE AND CONNECTOR WITH THE STRAIN RELIEF, MAKING SURE NO WIRES ARE PINCHED. SNAP THE TWO COVERS INTO POSITION
7. HOLDING THE CONNECTOR COVERS, SLIDE THE PLASTIC COVER DOWN THE CABLE. SLIDE THE CONNECTOR COVERS WITH THE CONNECTOR INTO THE PLASTIC COVER UNTIL IT SNAPS INTO PLACE

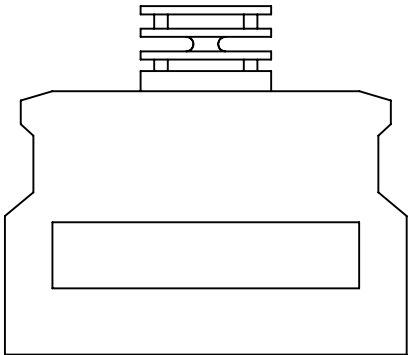

PLASTIC COVER

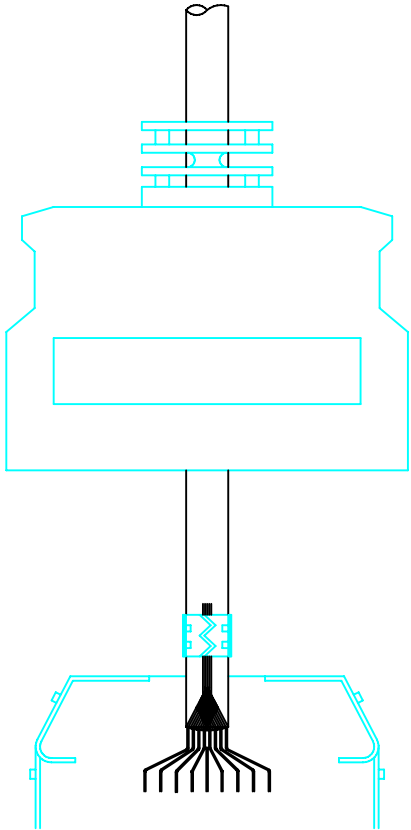

ITEM No. 1, 3, 4 & 5

STRAIN RELIEF  
FLATTENED FOR CLARITY

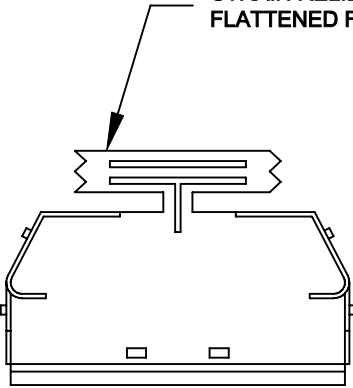

CONNECTOR COVER  
WITH STRAIN RELIEF

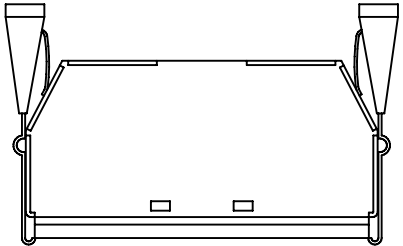

CONNECTOR COVER  
WITH SPRING LATCHES

**RoHS COMPLIANT**

**PLASTIC**

|  |   |                                       |                            |                          |
|--|---|---------------------------------------|----------------------------|--------------------------|
|  | THESE DRAWINGS AND SPECIFICATIONS ARE THE PROPERTY OF NorComp AND SHALL NOT BE REPRODUCED, COPIED OR USED AS THE BASIS FOR THE MANUFACTURE OF SALE OF APPARATUS WITHOUT WRITTEN PERMISSION. |                                       | DRAWN:<br><b>C. SMITH</b>  | DATE:<br><b>01-05-07</b> |
|  |   |                                       | CHECKED:<br><b>X</b>       | DATE:<br><b>X</b>        |
| <h1>NorComp</h1>   |   | SCALE:<br><b>N.T.S.</b>               | SHEET <b>1</b> OF <b>2</b> | REV <b>0</b>             |
|  |   | DWG NO. <b>BACKSHELL - 990 SERIES</b> |                            |                          |

**ASSEMBLY INSTRUCTIONS:**

1. PREPARE CABLE ENDS, CONNECT TO CONNECTOR
2. IF SPRING CLIPS ARE NOT IN PLACE, CLIP THEM IN
3. PLACE CABLE IN STRAIN RELIEF RECESS AREA MAKING SURE CABLE JACKET IS BELOW STRAIN RELIEF. ENSURE THE CABLE IS PRESSED INTO THE STRAIN RELIEF RECESS AREA
4. IF CABLE IS SHIELDED, FOLD SHIELD AND/OR GROUND WIRE BACK INTO STRAIN RELIEF AREA. CUT OFF ANY EXCESS WIRE SO IT DOES NOT STICK OUT OF THE CONNECTOR
5. PLACE STRAIN RELIEF CLAMP OVER CABLE. USING SCREWS PROVIDED, TIGHTEN CABLE CLAMP. CABLE CLAMP MAY BE INSTALLED UPSIDE DOWN FOR SMALLER CABLES
6. PLACE THE OTHER HALVE OF THE HOOD ON TOP OF THE FIRST HALF, MAKING SURE NO WIRES ARE PINCHED
7. HOLDING THE HOODS TOGETHER, INSERT THE MOUNTING SCREWS THROUGH THE TOP HOOD. TIGHTEN THE TWO HALVES TOGETHER

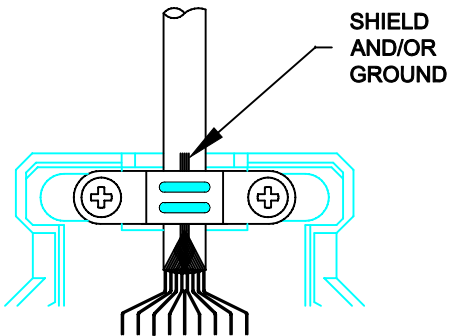
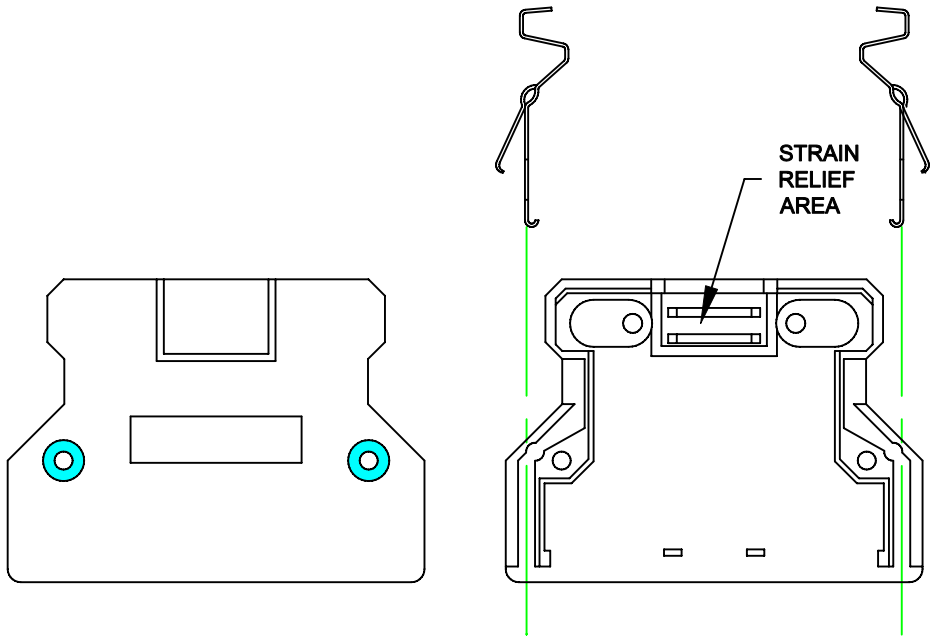

ITEM No. 3, 4 & 5

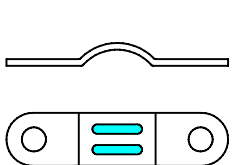

STRAIN RELIEF CLAMP

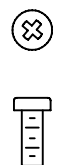

STRAIN RELIEF SCREW

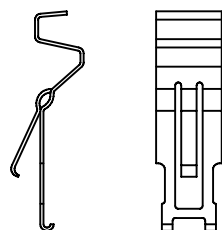

SPRING CLIP

**RoHS COMPLIANT**

**DIE CAST**

|                |   |                                       |                           |                          |
|----------------|---|---------------------------------------|---------------------------|--------------------------|
|                | THESE DRAWINGS AND SPECIFICATIONS ARE THE PROPERTY OF NorComp AND SHALL NOT BE REPRODUCED, COPIED OR USED AS THE BASIS FOR THE MANUFACTURE OF SALE OF APPARATUS WITHOUT WRITTEN PERMISSION. |                                       | DRAWN:<br><b>C. SMITH</b> | DATE:<br><b>01-05-07</b> |
|                |   |                                       | CHECKED:<br><b>X</b>      | DATE:<br><b>X</b>        |
| <b>NorComp</b> |   | SCALE:<br><b>N.T.S.</b>               | SHEET<br><b>2</b>         | OF<br><b>2</b>           |
|                |   | DWG NO. <b>BACKSHELL - 990 SERIES</b> |                           |                          |